



WinFan (M) Sdn. Bhd.

WINFAN Corrosion Resistant Fan



FRP

Fan series

High Performance . High Efficiency . Low Vibration . Low Noise



Winfan (M) Sdn. Bhd.

Corrosion Resistant Fan

**Committed to clean air,
Committed to green earth.**

Applications

- Semiconductor manufacturing
- TFT-LCD manufacturing.
- Petrol chemical manufacturing.
- Circuit board manufacturing.
- Chemical manufacturing & processing.
- Metal plating & finishing.
- Power plants
- Waste treatment facilities.

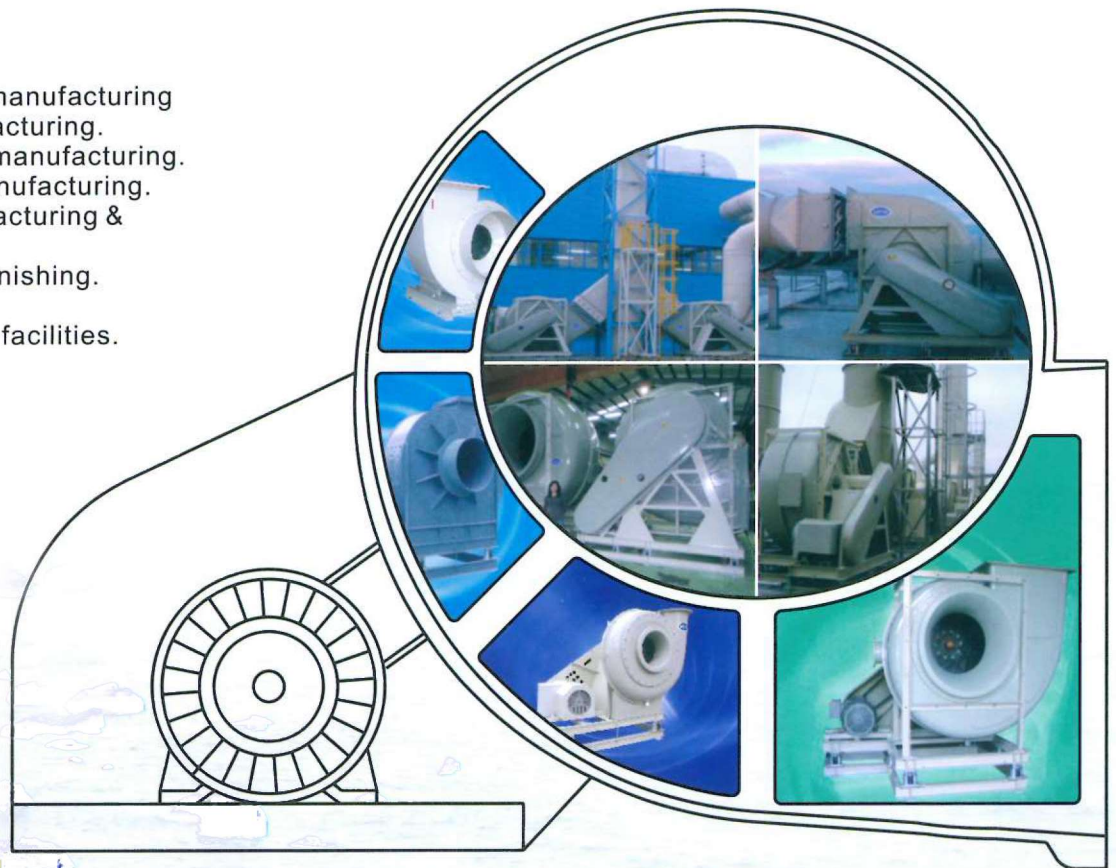

Quality assurance

- We comply with global quality assurance standard; each product is monitored, inspected and tested prior to shipment. We provide the most reliable products.
- A highly professional technical team in air pollution control industry, We committed to keep each product works in good function.

Winfan FRP Fans Advantages

- AMCA Certified rating-stable air performance.
- Cost efficiency-use Winfan FRP Fan reduce production cost.
- Fast delivery.
- Free test report- we provide free test report for each FRP Fan. Test items include performance curve, vibration, noise and bearing temperature.
- Every FRP fan is tested before delivery.
- Quick after-sale service - our professional and experience team can provide fast and efficient service

Product Features

- All fiberglass components are made in accordance with ASTM D4167 specifications (American Society for Testing Materials)
- Ratings shown are based on tests made in accordance with AMCA Publication 211.
- The back-pulling design makes Winfan FRP Fan easy to install and maintain.

Design Features

- Static Pressure to 325mmAq / 12.8" WG.
- Capacities to 2200CMM / 77500CFM.
- Temperatures to 80°C/ 176°F

PERFORMANCE DATA



If you require 30000CMH(600CMM) capacity and 1962 Pa(200 mmAq) static pressure ,then you can choose out the TF-361 model which is proper for you application according to the summarytable of performance curve below

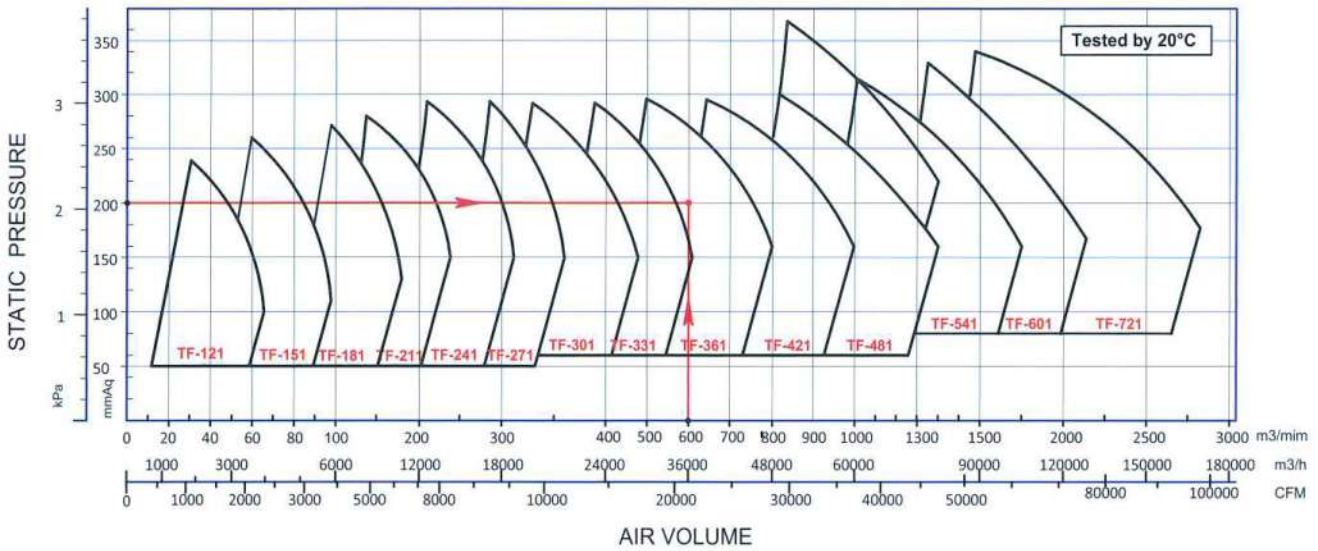

Selection:

Given 30 cmm/1059 CFM (A). at 100 mmAq/3.94".(B);

the fan will need to run at 2840 RPM (C) and use 1.0 BHP (D)

TF-121				Wheel diameter: 320 mm / 12.6 Inches wheel circumference: 1005 mm / 39.6 Inches						inlet Diameter: 300 mm / 11.8 Inches Outlet area: 0.071 m ² / 0.761 sq.ft											
Volume		Velocity		Static Pressure mmAq/Inches																	
CMM	CFM	m/s	fpm	50	1.97	75	2.95	100	3.94	125	4.92	150	5.91	175	6.89	200	7.87	225	8.86	250	9.84
				RPM	BHP	RPM	BHP	RPM	BHP	RPM	BHP	RPM	BHP	RPM	BHP	RPM	BHP	RPM	BHP	RPM	BHP
15	530	3.5	696	1917	0.3	2316	0.5	2660	0.7	2966	0.9	3245	1.1	3503	1.3	3744	1.6	3971	1.8	4186	2.0
20	706	4.7	928	1987	0.3	2368	0.6	2698	0.8	2995	1.0	3267	1.3	3519	1.5	3755	1.8	3978	2.1		
25	883	5.9	1160	2081	0.4	2442	0.6	2760	0.9	3046	1.2	3310	1.4	3556	1.7	3786	2.0				
A 30	1059	7.1	1392	2193	0.5	2536	0.7	C 2840	D 1.0	3116	1.3	3371	1.6								
35	1236	8.3	1624	2320	0.6	2645	0.8	2936	1.1	3201	1.4	3448	1.8								
40	1412	9.4	1856	2459	0.7	2767	0.9	3045	1.2	3300	1.6	3538	1.9								
45	1589	10.6	2088	2606	0.8	2899	1.1	3165	1.4	3411	1.8										
50	1765	11.8	2320	2762	0.9	3040	1.2	3295	1.6	3531	1.9										
55	1942	13.0	2552	2923	1.1	3189	1.4	3432	1.8												
60	2118	14.1	2784	3091	1.3	3343	1.6														
65	2295	15.3	3016	3262	1.5																

inlet Diameter

TF-151				Wheel diameter: 400 mm / 15.7 Inches wheel circumference: 1257 mm / 49.5 Inches						inlet Diameter: 350 mm / 13.8 Inches Outlet area: 0.096 m ² / 1.035 sq.ft											
Volume		Velocity		Static Pressure mmAq/Inches																	
CMM	CFM	m/s	fpm	50	1.97	75	2.95	100	3.94	125	4.92	150	5.91	175	6.89	200	7.87	225	8.86	250	9.84
				RPM	BHP	RPM	BHP	RPM	BHP	RPM	BHP	RPM	BHP	RPM	BHP	RPM	BHP	RPM	BHP	RPM	BHP
30	1059	5.2	1023	1549	0.5	1837	0.8	2086	1.1	2310	1.4	2514	1.8	2704	2.1	2882	2.5	3050	2.9	3210	3.2
40	1412	6.9	1364	1661	0.7	1931	1.0	2168	1.4	2382	1.7	2578	2.1	2762	2.6	2934	3.0	3097	3.4	3253	3.9
50	1765	8.7	1705	1791	0.8	2046	1.2	2271	1.6	2476	2.1	2665	2.5	2841	3.0	3008	3.5	3166	4.0		
60	2118	10.4	2045	1934	1.1	2176	1.5	2391	2.0	2587	2.4	2768	3.0	2938	3.5	3166	4.2	3302	4.8		
70	2471	12.1	2386	2087	1.3	2317	1.8	2523	2.3	2710	2.9	2885	3.4	3049	4.0	3204	4.6				
80	2824	13.9	2727	2247	1.7	2467	2.2	2664	2.8	2844	3.3	3013	3.9	3171	4.6	3321	5.2				
90	3177	15.6	3068	2413	2.1	2623	2.7	2812	3.3	2986	3.9	3149	4.5								
100	3530	17.3	3409	2583	2.6	2785	3.2	2967	3.8	3135	4.5										
110	3883	19.1	3750	2757	3.1	2951	3.8	3127	4.5	3289	5.2										
120	4236	20.8	4091	2935	3.8	3121	4.5	3291	5.3												
130	4589	22.5	4432	3115	4.5	3294	5.3														

"Performance certified is for installation type A:free inlet,free outlet, Power rating (BHP) does not include transmission losses Performance ratings do not include the effects of appurtenances (accessories)."

PERFORMANCE DATA

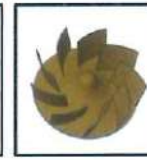

TF-181				Wheel diameter: 480 mm / 18.9 Inches wheel circumference: 1508 mm / 59.4 Inches								inlet Diameter: 450 mm / 17.7 Inches Outlet area: 0.159 m ² / 1.711 sq.ft									
				Static Pressure mmAq/Inches																	
Volume		Velocity		50	1.97	75	2.95	100	3.94	125	4.92	150	5.91	175	6.89	200	7.87	225	8.86	250	9.84
CMM	CFM	m/s	fpm	RPM	BHP	RPM	BHP	RPM	BHP	RPM	BHP	RPM	BHP	RPM	BHP	RPM	BHP	RPM	BHP	RPM	BHP
80	2824	8.4	1650	1488	1.5	1671	2.1	1835	2.7	1986	3.4	2125	4.1	2256	4.9	2379	5.7	2496	6.5	2608	7.4
100	3530	10.5	2062	1675	2.2	1840	2.8	1992	3.6	2132	4.3	2263	5.1	2386	6.0	2504	6.8	2616	7.7	2723	8.7
120	4236	12.6	2475	1877	3.0	2027	3.8	2166	4.6	2296	5.5	2419	6.4	2535	7.3	2646	8.2	2753	9.2		
130	4589	13.6	2681	1982	3.6	2125	4.4	2259	5.3	2384	6.2	2503	7.1	2616	8.1	2724	9.1				
140	4942	14.7	2887	2090	4.2	2227	5.1	2354	6.0	2475	6.9	2590	7.9	2700	8.9						
150	5295	15.7	3093	2200	4.8	2330	5.8	2453	6.8	2569	7.8	2680	8.8	2787	9.9						
160	5648	16.8	3300	2312	5.6	2436	6.6	2554	7.6	2666	8.7	2774	9.8								
170	6001	17.8	3506	2425	6.5	2544	7.5	2657	8.6	2766	9.7	2869	10.8								
180	6354	18.9	3712	2540	7.4	2654	8.5	2763	9.6	2867	10.8	2967	12.0								
200	7060	21.0	4125	2772	9.6	2877	10.8	2978	12.0	3075	13.3										
210	7413	22.0	4331	2889	10.8	2991	12.1	3088	13.4	3182	14.7										

TF-211				Wheel diameter: 520 mm / 20.5 Inches wheel circumference: 1634 mm / 64.3 Inches								inlet Diameter: 500 mm / 19.7 Inches Outlet area: 0.196 m ² / 2.113 sq.ft									
				Static Pressure mmAq/Inches																	
Volume		Velocity		50	1.97	75	2.95	100	3.94	125	4.92	150	5.91	175	6.89	200	7.87	225	8.86	250	9.84
CMM	CFM	m/s	fpm	RPM	BHP	RPM	BHP	RPM	BHP	RPM	BHP	RPM	BHP	RPM	BHP	RPM	BHP	RPM	BHP	RPM	BHP
90	3177	7.6	1503	1128	1.4	1322	2.2	1494	3.0	1649	3.9	1792	4.8	1926	5.8	2051	6.8	2170	7.9	2283	9.0
100	3530	8.5	1670	1161	1.6	1350	2.4	1517	3.3	1669	4.2	1809	5.1	1940	6.2	2064	7.3	2181	8.4	2293	9.5
110	3883	9.3	1838	1198	1.8	1380	2.6	1543	3.6	1692	4.5	1829	5.5	1958	6.6	2080	7.7	2195	8.9		
120	4236	10.2	2005	1237	2.0	1414	2.9	1572	3.8	1717	4.9	1852	5.9	1978	7.0	2098	8.2	2211	9.4		
130	4589	11.0	2172	1278	2.3	1449	3.2	1603	4.2	1745	5.2	1877	6.3	2001	7.4	2119	8.7				
140	4942	11.9	2339	1321	2.5	1487	3.5	1637	4.5	1776	5.6	1905	6.7	2027	7.9	2142	9.2				
150	5295	12.7	2506	1366	2.8	1527	3.8	1673	4.9	1808	6.0	1935	7.2	2054	8.4	2167	9.7				
160	5648	13.6	2673	1412	3.2	1568	4.2	1711	5.3	1843	6.5	1966	7.6	2083	8.9	2195	10.3				
170	6001	14.4	2840	1460	3.5	1611	4.6	1750	5.7	1879	6.9	2000	8.2	2115	9.5	2224	10.9				
180	6354	15.3	3007	1509	3.9	1656	5.0	1791	6.2	1917	7.5	2035	8.7	2148	10.1						
200	7060	17.0	3341	1610	4.8	1748	6.0	1877	7.3	1997	8.6	2111	9.9								

TF-241				Wheel diameter: 650 mm / 25.6 Inches wheel circumference: 2042 mm / 80.4 Inches								inlet Diameter: 600 mm / 23.6 Inches Outlet area: 0.283 m ² / 3.042 sq.ft									
				Static Pressure mmAq/Inches																	
Volume		Velocity		75	2.95	100	3.94	125	4.92	150	5.91	175	6.89	200	7.87	225	8.86	250	9.84	275	10.83
CMM	CFM	m/s	fpm	RPM	BHP	RPM	BHP	RPM	BHP	RPM	BHP	RPM	BHP	RPM	BHP	RPM	BHP	RPM	BHP	RPM	BHP
120	4236	7.1	1392	1129	3.2	1265	4.4	1388	5.7	1501	7.0	1606	8.5	1705	10.0	1798	11.6	1887	13.2	1972	14.9
140	4942	8.3	1624	1178	3.8	1307	5.0	1426	6.4	1536	7.8	1639	9.3	1736	10.9	1827	12.6	1915	14.3	1998	16.1
160	5648	9.4	1856	1233	4.4	1356	5.7	1469	7.1	1575	8.7	1675	10.3	1770	11.9	1860	13.7	1946	15.4		
180	6354	10.6	2088	1295	5.1	1410	6.5	1518	8.0	1621	9.6	1717	11.3	1809	13.0	1897	14.9				
200	7060	11.8	2320	1362	5.9	1470	7.4	1573	9.0	1671	10.7	1764	12.5	1853	14.3						
220	7766	13.0	2552	1434	6.9	1535	8.5	1633	10.2	1726	11.9	1815	13.8	1901	15.7						
240	8472	14.1	2784	1509	8.0	1604	9.7	1697	11.4	1785	13.3	1871	15.2								
260	9178	15.3	3016	1588	9.2	1677	11.0	1765	12.9	1849	14.8	1931	16.8								
280	9884	16.5	3248	1669	10.6	1754	12.5	1836	14.4	1916	16.5	1994	18.6								
300	10590	17.7	3480	1753	12.2	1832	14.2	1910	16.2	1987	18.3										
320	11296	18.9	3712	1838	13.9	1913	16.0	1988	18.1												

"Performance certified is for installation type A: free inlet, free outlet, Power rating (BHP) does not include transmission losses
Performance ratings do not include the effects of appurtenances (accessories)."

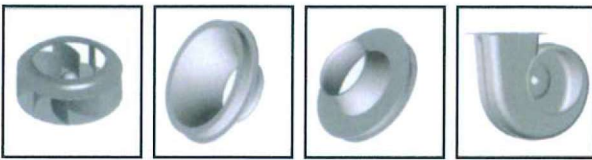

TF-271				Wheel diameter: 720 mm / 28.3 Inches wheel circumference: 2262 mm / 89.1 Inches								inlet Diameter: 650 mm / 25.6 Inches Outlet area: 0.332 m ² / 3.571 sq.ft									
				Static Pressure mmAq/Inches																	
Volume		Velocity		75	2.95	100	3.94	125	4.92	150	5.91	175	6.89	200	7.87	225	8.86	250	9.84	275	10.83
CMM	CFM	m/s	fpm	RPM	BHP	RPM	BHP	RPM	BHP	RPM	BHP	RPM	BHP	RPM	BHP	RPM	BHP	RPM	BHP	RPM	BHP
140	4942	7.0	1384	1037	3.6	1173	4.9	1297	6.3	1410	7.8	1516	9.3	1615	10.9	1709	12.6	1798	14.3	1884	16.0
160	5648	8.0	1582	1063	4.0	1195	5.4	1315	6.9	1426	8.5	1530	10.2	1627	11.9	1719	13.6	1808	15.5	1892	17.3
180	6354	9.0	1779	1092	4.5	1221	6.0	1338	7.6	1446	9.3	1547	11.1	1643	12.9	1733	14.7	1820	16.7		
200	7060	10.0	1977	1125	5.1	1249	6.7	1363	8.4	1469	10.1	1568	12.0	1661	13.9	1750	15.9	1835	17.9		
220	7766	11.0	2175	1161	5.7	1281	7.4	1391	9.2	1494	11.0	1591	13.0	1683	15.0	1770	17.1				
240	8472	12.1	2372	1199	6.4	1315	8.1	1422	10.0	1523	12.0	1617	14.0	1707	16.1	1793	18.3				
260	9178	13.1	2570	1239	7.2	1351	9.0	1456	11.0	1554	13.0	1646	15.1	1734	17.3						
280	9884	14.1	2768	1280	8.0	1390	10.0	1491	12.0	1586	14.1	1677	16.3	1763	18.6						
300	10590	15.1	2965	1324	9.0	1430	10.9	1528	13.1	1621	15.3	1709	17.6								
320	11296	16.1	3163	1369	10.0	1471	12.1	1567	14.3	1658	16.7	1744	19.0								
340	12002	17.1	3361	1415	11.1	1514	13.3	1608	15.7	1696	18.1										

TF-301				Wheel diameter: 800 mm / 31.5 Inches wheel circumference: 2513 mm / 98.9 Inches								inlet Diameter: 750 mm / 29.5 Inches Outlet area: 0.442 m ² / 4.754 sq.ft									
				Static Pressure mmAq/Inches																	
Volume		Velocity		75	2.95	100	3.94	125	4.92	150	5.91	175	6.89	200	7.87	225	8.86	250	9.84	275	10.83
CMM	CFM	m/s	fpm	RPM	BHP	RPM	BHP	RPM	BHP	RPM	BHP	RPM	BHP	RPM	BHP	RPM	BHP	RPM	BHP	RPM	BHP
275	9708	10.4	2042	1058	7.4	1149	9.4	1234	11.6	1315	13.9	1391	16.3	1464	18.8	1534	21.4	1061	24.1	1666	26.9
300	10590	11.3	2227	1104	8.4	1191	10.5	1273	12.8	1350	15.2	1424	17.7	1495	20.3	1563	23.0	1629	25.8	1692	28.6
325	11473	12.3	2413	1153	9.5	1235	11.8	1314	14.1	1389	16.6	1460	19.2	1529	21.9	1595	24.7	1658	27.6		
350	12355	13.2	2599	1203	10.8	1282	13.1	1357	15.6	1429	18.2	1498	20.9	1565	23.7	1629	26.6	1691	29.5		
375	13238	14.1	2784	1255	12.2	1331	14.6	1403	17.2	1472	19.9	1539	22.7	1603	25.6	1665	28.6				
400	14120	15.1	2970	1309	13.7	1381	16.3	1450	19.0	1517	21.8	1581	24.6	1643	27.6						
425	15003	16.0	3155	1364	15.4	1433	18.1	1499	20.9	1563	23.8	1625	26.8	1686	29.9						
450	15885	17.0	3341	1420	17.3	1486	20.1	1550	23.0	1611	26.0	1671	29.1								
475	16768	17.9	3527	1477	19.4	1540	22.3	1601	25.3	1661	28.4										
500	17650	18.9	3712	1535	21.6	1595	24.6	1654	27.8												
525	18533	19.8	3898	1593	24.1	1652	27.2														

TF-331				Wheel diameter: 880 mm / 34.65 Inches wheel circumference: 2765 mm / 108.8 Inches								inlet Diameter: 800 mm / 31.5 Inches Outlet area: 0.503 m ² / 5.409 sq.ft									
				Static Pressure mmAq/Inches																	
Volume		Velocity		75	2.95	100	3.94	125	4.92	150	5.91	175	6.89	200	7.87	225	8.86	250	9.84	275	10.83
CMM	CFM	m/s	fpm	RPM	BHP	RPM	BHP	RPM	BHP	RPM	BHP	RPM	BHP	RPM	BHP	RPM	BHP	RPM	BHP	RPM	BHP
325	11473	10.8	2121	952	7.8	1049	10.1	1137	12.6	1219	15.1	1295	17.8	1368	20.5	1437	23.4	1503	26.3	1566	29.2
350	12355	11.6	2284	978	8.5	1073	11.0	1160	13.6	1240	16.2	1315	19.0	1387	21.9	1455	24.8	1520	27.8	1582	30.9
375	13238	12.4	2447	1006	9.3	1099	11.9	1184	14.6	1262	17.4	1337	20.3	1407	23.3	1474	26.3	1538	29.4	1600	32.7
400	14120	13.3	2610	1.34	10.2	1125	12.9	1208	15.7	1286	18.6	1359	21.6	1428	24.7	1494	27.9	1557	31.1		
425	15003	14.1	2773	1063	11.2	1152	14.0	1234	16.9	1311	20.0	1382	23.1	1450	26.3	1515	29.6	1578	32.9		
450	15885	14.9	2936	1093	12.2	1181	15.2	1261	18.2	1336	21.4	1407	24.6	1474	27.9	1538	31.3				
475	16768	15.7	3100	1124	13.3	1209	16.4	1288	19.6	1362	22.8	1432	26.2	1498	29.6						
500	17650	16.6	3263	1155	14.5	1239	17.7	1316	21.0	1389	24.4	1457	27.9	1523	31.4						
525	18533	17.4	3426	1186	15.8	1269	19.1	1345	22.5	1416	26.0	1484	29.6								
550	19415	18.2	3589	1218	17.2	1299	20.6	1374	24.2	1445	27.8	1511	31.5								
575	20298	19.1	3752	1250	18.6	1330	22.2	1404	25.9	1473	29.6										

"Performance certified is for installation type A: free inlet, free outlet, Power rating (BHP) does not include transmission losses
Performance ratings do not include the effects of appurtenances (accessories)."



PERFORMANCE DATA

TF-361				Wheel diameter: 970 mm / 38.2 Inches wheel circumference: 3047 mm / 120 Inches								inlet Diameter: 900 mm / 35.4 Inches Outlet area: 0.636 m ² / 6.845 sq.ft									
				Static Pressure mmAq/Inches																	
Volume		Velocity		75	2.95	100	3.94	125	4.92	150	5.91	175	6.89	200	7.87	225	8.86	250	9.84	275	10.83
CMM	CFM	m/s	fpm	RPM	BHP	RPM	BHP	RPM	BHP	RPM	BHP	RPM	BHP	RPM	BHP	RPM	BHP	RPM	BHP	RPM	BHP
350	12355	9.2	1805	821	9.5	903	12.5	980	15.8	1052	19.0	1119	22.5	1183	26.2	1243	30.3	1301	34.0	1356	38.1
400	14120	10.5	2062	867	11.3	944	14.5	1017	17.8	1085	21.4	1150	25.1	1212	29.0	1271	33.0	1327	37.2	1381	41.5
450	15885	11.8	2320	917	13.4	990	16.8	1058	20.4	1123	24.1	1185	28.1	1245	32.1	1302	36.4	1357	40.7	1409	45.2
500	17650	13.1	2578	972	15.8	1039	19.4	1103	23.3	1165	27.2	1225	31.4	1282	35.7	1337	40.1	1390	44.7	1453	48.2
550	19415	14.4	2836	1029	18.7	1092	22.5	1152	26.5	1211	30.7	1267	35.1	1322	39.6	1375	44.2	1436	46.4	1488	51.4
575	20298	15.1	2965	1059	20.2	1120	24.2	1178	28.3	1235	32.6	1290	37.1	1343	41.7	1395	46.5	1452	47.2		
600	21180	15.7	3093	1089	21.9	1148	26.0	1205	30.3	1260	34.7	1314	39.2	1366	44.0	1416	48.8	1470	48.7		
650	22945	17.0	3351	1151	25.6	1206	30.0	1260	34.4	1312	39.1	1363	43.9	1413	48.8	1457	50.1				
700	24710	18.3	3609	1215	29.9	1267	34.4	1317	39.1	1366	44.0	1415	49.0	1448	52.9						
750	26475	19.6	3867	1281	34.6	1329	39.4	1376	44.4	1423	49.5	1469	54.7								
800	28240	21.0	4125	1347	39.9	1393	45.0	1438	50.2	1482	55.5										

TF-421				Wheel diameter: 1090 mm / 42.9 Inches wheel circumference: 3424 mm / 135 Inches								inlet Diameter: 1000 mm / 39.4 Inches Outlet area: 0.785 m ² / 8.451 sq.ft									
				Static Pressure mmAq/Inches																	
Volume		Velocity		100	3.94	125	4.92	150	5.91	175	6.89	200	7.87	225	8.86	250	9.84	275	10.83	300	11.81
CMM	CFM	m/s	fpm	RPM	BHP	RPM	BHP	RPM	BHP	RPM	BHP	RPM	BHP	RPM	BHP	RPM	BHP	RPM	BHP	RPM	BHP
550	19415	11.7	2297	869	20.3	931	24.8	989	29.4	1045	34.3	1099	39.4	1150	44.7	1199	50.1	1247	55.7	1292	61.5
600	21180	12.7	2506	902	22.8	961	27.5	1018	32.4	1072	37.5	1124	42.8	1174	48.2	1222	53.9	1268	59.7	1313	65.6
650	22945	13.8	2715	938	25.6	995	30.5	1049	35.6	1101	40.9	1151	46.4	1199	52.1	1246	58.0	1291	64.0	1335	70.1
700	24710	14.9	2923	976	28.8	1030	33.9	1081	39.2	1131	44.7	1180	50.4	1227	56.3	1272	62.4	1316	68.6		
750	26475	15.9	3132	1015	32.3	1066	37.6	1116	43.1	1164	48.9	1210	54.8	1256	60.9	1300	67.2				
800	28240	17.0	3341	1056	36.1	1105	41.7	1152	47.4	1198	53.4	1243	59.6	1287	65.9	1329	72.3				
850	30005	18.0	3550	1098	40.3	1144	46.1	1190	52.1	1234	58.3	1277	64.7	1319	71.2						
900	31770	19.1	3759	1141	45.0	1185	51.0	1229	57.3	1271	63.7	1313	70.2	1354	77.0						
950	33535	20.2	3967	1185	50.1	1227	56.3	1269	62.8	1310	69.4	1350	76.3								
1000	35300	21.2	4176	1230	55.6	1270	62.1	1310	68.8	1349	75.7	1388	82.7								
1050	37065	22.3	4385	1276	61.6	1314	68.4	1353	75.3	1390	82.4										

TF-481				Wheel diameter: 1300 mm / 51.2 Inches wheel circumference: 4084 mm / 161 Inches								inlet Diameter: 1200 mm / 47.2 Inches Outlet area: 1.131 m ² / 12.17 sq.ft									
				Static Pressure mmAq/Inches																	
Volume		Velocity		125	4.92	150	5.91	175	6.89	200	7.87	225	8.86	250	9.84	275	10.83	300	11.81	325	12.80
CMM	CFM	m/s	fpm	RPM	BHP	RPM	BHP	RPM	BHP	RPM	BHP	RPM	BHP	RPM	BHP	RPM	BHP	RPM	BHP	RPM	BHP
800	28240	11.8	2320	787	36.1	835	42.9	882	49.9	926	57.2	969	64.7	1010	72.6	1050	80.6	1088	88.9	1125	97.4
900	31770	13.3	2610	824	41.9	870	49.0	914	58.5	957	64.2	998	72.2	1037	80.4	1076	88.8	1113	97.5		
1000	35300	14.7	2900	865	48.5	908	56.1	950	64.0	991	72.1	1030	80.5	1068	89.1	1105	98.0				
1050	37065	15.5	3045	887	52.2	929	60.0	969	68.1	1009	76.4	1047	85.0	1084	93.9	1120	103.0				
1100	38830	16.2	3190	909	56.1	950	64.2	989	72.5	1027	81.0	1065	89.9	1101	98.9						
1150	40595	16.9	3335	932	60.3	971	68.6	1010	77.1	1047	85.9	1083	94.9	1119	104.2						
1200	42360	17.7	3480	955	64.8	993	73.3	1031	82.0	1067	91.0	1103	100.3								
1250	44125	18.4	3625	979	69.6	1016	78.3	1052	87.3	1088	96.5	1123	106.0								
1300	45890	19.2	3770	1004	74.6	1040	83.6	1075	92.8	1109	102.2										
1400	49420	20.6	4060	1054	85.7	1088	95.1	1121	104.8												
1500	52950	22.1	4350	1105	98.1	1137	108.0														

"Performance certified is for installation type A: free inlet, free outlet, Power rating (BHP) does not include transmission losses Performance ratings do not include the effects of appurtenances (accessories)."



TF-541				Wheel diameter: 1450 mm / 57.1 Inches wheel circumference: 4555 mm / 179 Inches								inlet Diameter: 1350 mm / 53.1 Inches Outlet area: 1.431 m ² / 15.4 sq.ft									
				Volume		Velocity		Static Pressure mmAq/Inches													
CMM	CFM	m/s	fpm	100	3.94	125	4.92	150	5.91	175	6.89	200	7.87	225	8.86	250	9.84	275	10.83	300	11.81
				RPM	BHP	RPM	BHP	RPM	BHP	RPM	BHP	RPM	BHP	RPM	BHP	RPM	BHP	RPM	BHP	RPM	BHP
900	31770	10.5	2063	584	25.5	637	32.2	686	39.3	732	46.5	775	53.9	816	61.6	856	69.4	894	77.4	930	85.5
1000	35300	11.6	2292	601	28.2	652	35.4	700	42.9	745	50.6	787	58.5	827	66.7	866	75.0	903	83.5	939	92.1
1100	38830	12.8	2521	620	31.0	669	38.7	715	46.8	759	54.9	800	63.3	840	72.0	878	80.8	914	89.9	949	98.9
1200	42360	14.0	2751	639	34.1	687	42.2	732	50.8	775	59.4	815	68.3	854	77.4	891	86.7	926	96.2	961	105.8
1300	45890	15.1	2980	660	37.3	707	46.0	750	55.1	792	64.1	831	73.5	869	83.1	905	92.9	940	102.8		
1400	49420	16.3	3209	682	40.7	727	50.0	769	59.4	810	69.0	848	78.8	885	89.0	920	99.2				
1500	52950	17.5	3438	704	44.3	748	54.0	789	64.0	828	74.1	866	84.5	902	95.1						
1600	56480	18.6	3667	727	48.2	770	58.4	810	68.9	848	79.5	885	90.4								
1700	60010	19.8	3897	751	52.3	792	63.1	832	74.0	869	85.1										
1800	63540	21.0	4126	775	56.6	816	67.8	854	79.4												
1900	67070	22.1	4355	800	61.3	839	73.0														

TF-601				Wheel diameter: 1610 mm / 63.4 Inches wheel circumference: 5058 mm / 199 Inches								inlet Diameter: 1500 mm / 59.1 Inches Outlet area: 1.767 m ² / 19.01 sq.ft									
				Volume		Velocity		Static Pressure mmAq/Inches													
CMM	CFM	m/s	fpm	125	4.92	150	5.91	175	6.89	200	7.87	225	8.86	250	9.84	275	10.83	300	11.81	325	12.80
				RPM	BHP	RPM	BHP	RPM	BHP	RPM	BHP	RPM	BHP	RPM	BHP	RPM	BHP	RPM	BHP	RPM	BHP
1200	42360	11.3	2227	623	46.6	665	55.2	705	64.1	742	73.2	778	82.6	812	92.3	845	102.2	876	112.2	907	122.5
1300	45890	12.3	2413	639	51.3	680	60.4	719	69.7	756	79.4	791	89.2	824	99.3	857	109.6	888	120.1	918	130.9
1400	49420	13.2	2599	655	56.6	696	66.1	734	75.8	770	85.9	805	96.2	838	106.7	869	117.5	900	128.5	930	139.6
1500	52950	14.1	2784	672	62.3	712	72.2	749	82.4	785	92.9	819	103.7	852	114.6	883	125.8	913	137.3		
1600	56480	15.1	2970	690	68.5	729	78.8	766	89.5	801	100.4	834	111.6	866	123.0	897	134.7				
1700	60010	16.0	3155	708	75.2	746	86.0	782	97.1	817	108.5	850	120.1	881	131.9	912	144.0				
1800	63540	17.0	3341	727	82.4	764	93.7	800	105.3	833	117.1	866	129.1	897	141.4						
1900	67070	17.9	3527	746	90.3	783	102.0	817	114.0	851	126.3										
2000	70600	18.9	3712	765	98.8	801	111.0	836	123.4												
2100	74130	19.8	3898	785	107.9	821	120.6														
2200	77660	20.7	4083	806	117.8	840	130.8														

TF-721				Wheel diameter: 1800 mm / 70.9 Inches wheel circumference: 5655 mm / 223 Inches								inlet Diameter: 1800 mm / 70.9 Inches Outlet area: 2.545 m ² / 27.38 sq.ft									
				Volume		Velocity		Static Pressure mmAq/Inches													
CMM	CFM	m/s	fpm	125	4.92	150	5.91	175	6.89	200	7.87	225	8.86	250	9.84	275	10.83	300	11.81	325	12.80
				RPM	BHP	RPM	BHP	RPM	BHP	RPM	BHP	RPM	BHP	RPM	BHP	RPM	BHP	RPM	BHP	RPM	BHP
1300	45890	8.5	1676	446	49.2	480	59.6	512	70.4	542	81.6	571	93.0	598	104.8	624	116.9	649	129.2	674	141.7
1450	51185	9.5	1869	456	54.6	490	65.7	521	77.2	551	89.1	579	101.3	606	113.8	632	126.6	657	139.6	680	152.9
1600	56480	10.5	2062	468	60.4	501	72.2	531	84.5	561	97.0	588	109.9	615	123.2	640	136.7	664	150.4	688	164.5
1750	61775	11.5	2256	480	66.7	512	79.3	542	92.2	571	105.5	598	119.1	624	133.0	649	147.2	673	161.7	696	176.4
1900	67070	12.4	2449	493	73.6	525	86.8	554	100.4	582	114.4	609	128.7	634	143.3	659	158.2	683	173.4		
2050	72365	13.4	2642	507	81.1	538	95.0	567	109.3	594	123.9	620	138.9	645	154.2	669	169.9				
2200	77660	14.4	2836	521	89.1	551	103.7	579	118.7	606	134.1	632	149.8	657	165.8						
2350	82955	15.4	3029	536	97.9	565	113.2	593	128.9	619	144.9	645	161.3	669	178.0						
2500	88250	16.4	3222	551	107.3	580	123.3	607	139.7	633	156.5	658	173.6								
2650	93545	17.4	3416	566	117.5	595	134.3	621	151.4	647	168.8	671	186.6								
2800	98840	18.3	3609	582	128.5	610	146.0	636	163.8	661	181.9										

"Performance certified is for installation type A: free inlet, free outlet, Power rating (BHP) does not include transmission losses
Performance ratings do not include the effects of appurtenances (accessories)."

DIMENSION DRAWING

TF-121 151 181 211 241 271 301 331 Belt Drive

Side view from the inlet

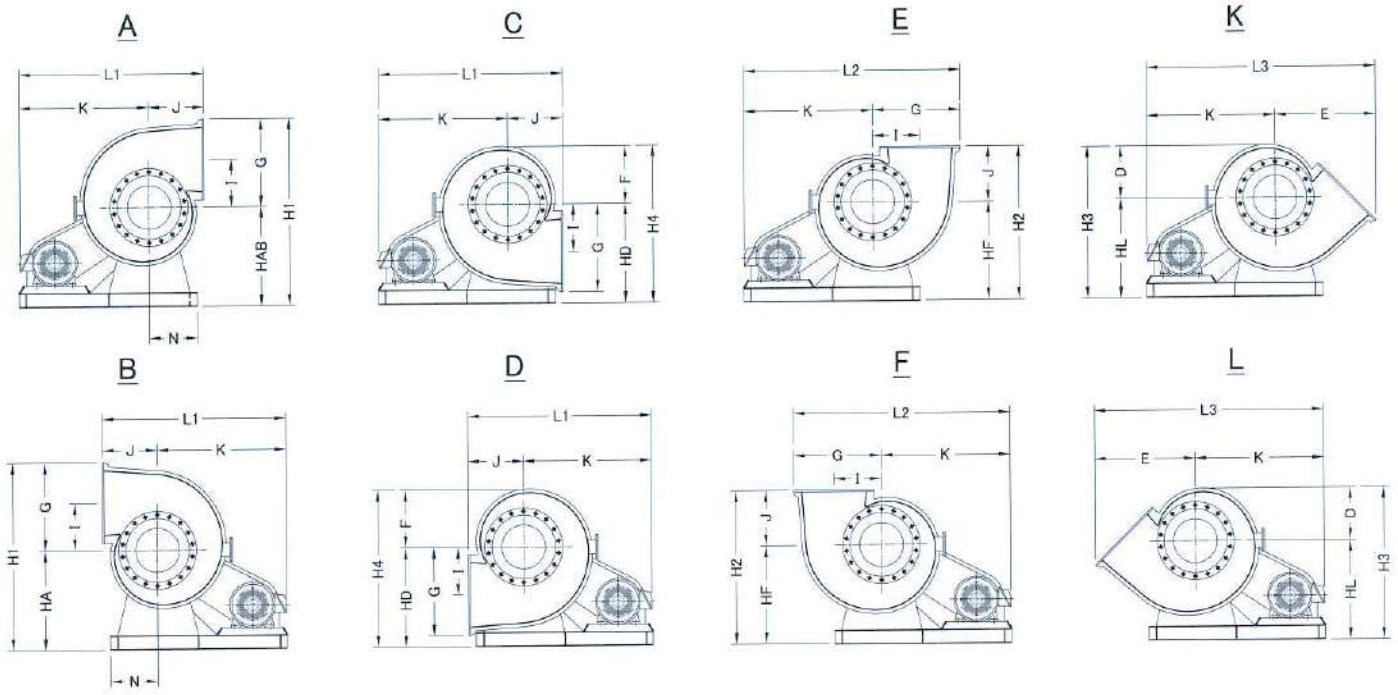

BODY

OUTLET

BASE-ACEK

BASE-BDFL

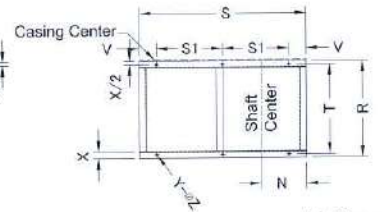
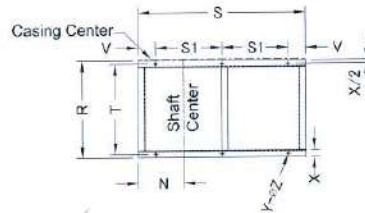
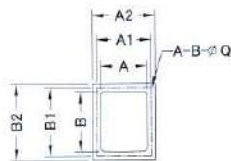
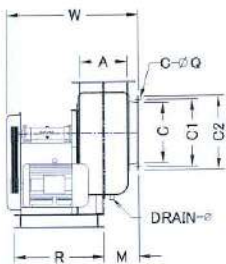

Unit : mm

MODEL	BODY																				BEARING		
	L1	H1	L2	H2	L3	H3	H4	W	HA	HF	HL	HD	D	E	F	G	I	J	K	M	N	L.S	O.S
TF-121B	845	840	965	720	1042	700	720	730	450	450	450	450	250	467	270	390	195	270	575	198	225	6308	6307
TF-151B	1041	1046	1219	868	1299	867	894	830	550	550	550	550	235	576	344	496	271	318	723	240	258	6308	6307
TF-181B	1187	1270	1420	1037	1512	1022	1109	830	650	650	650	700	372	712	409	620	335	387	900	295	300	6309	6307
TF-211B	1320	1390	1560	1150	1676	1122	1265	1134	700	700	700	800	422	806	465	690	380	450	965	324	380	6311	6309
TF-241B	1465	1270	1755	1037	1877	1022	1109	1204	800	800	800	900	482	912	531	790	430	500	965	347	380	6311	6309
TF-271B	1580	1600	1870	1410	2017	1377	1526	1322	750	850	850	950	527	997	576	850	460	560	1020	377	430	6313	6311
TF-301B	1726	1750	2050	1576	2214	1505	1715	1381	800	950	950	1100	555	1114	615	950	480	626	1100	406	450	6313	6311
TF-331B	1820	1990	2160	1800	2350	1737	1920	1427	950	1100	1100	1100	637	1230	702	970	570	700	1120	432	480	6313	6311

MODEL	OUTLET FLANGE						INLET FLANGE					BASE						DRAIN	W.T	
	A	B	A1	B1	A2	B2	A-B-øQ	øC	øC1	øC2	C-øQ	R	S	S1	T	V	X	Y-øZ	ø	(kg)
TF-121B	220	300	265	345	310	390	14-ø11	300	345	390	12-ø11	500	800	300	460	100	40	6-ø16	3/4"	55
TF-151B	280	350	330	400	380	450	14-ø11	350	400	450	12-ø11	530	980	390	490	100	40	6-ø16	3/4"	105
TF-181B	350	450	410	510	470	570	22-ø11	450	500	550	16-ø11	660	1100	450	610	100	50	6-ø16	1"	125
TF-211B	400	500	467	567	520	620	22-ø11	500	550	600	20-ø11	760	1250	520	710	100	50	6-ø16	1"	185
TF-241B	490	600	550	660	610	720	24-ø11	600	650	700	22-ø11	800	1350	575	750	100	50	6-ø16	1"	260
TF-271B	500	650	565	715	630	780	30-ø11	650	710	770	24-ø11	855	1450	625	805	100	50	6-ø16	1"	310
TF-301B	550	800	620	870	690	940	32-ø11	750	800	850	27-ø11	900	1550	625	835	150	65	6-ø16	1"	380
TF-331B	600	800	670	870	740	940	32-ø11	800	870	940	32-ø11	920	1600	650	855	150	65	6-ø16	1"	450



TF-361 421 481 541 601 721 Belt Drive

Side view from the inlet

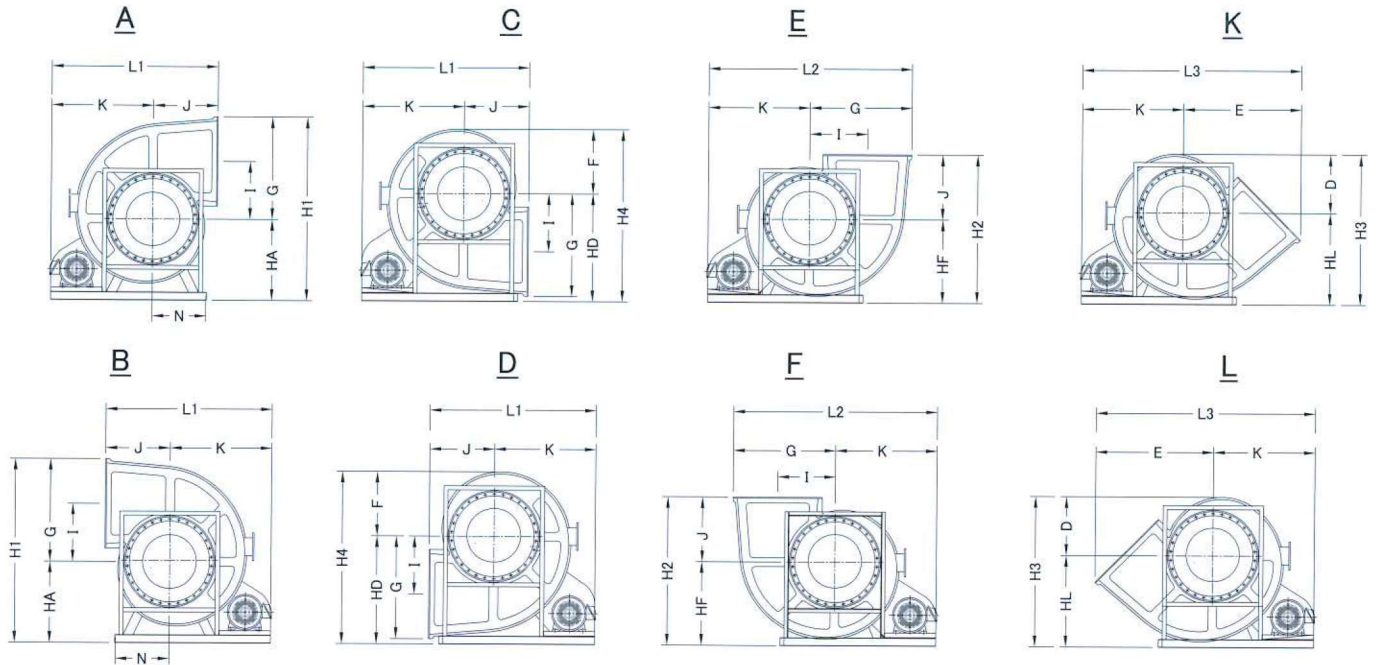

BODY

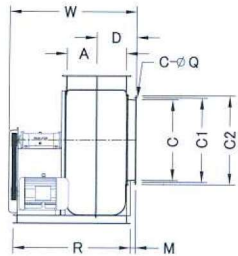

OUTLET

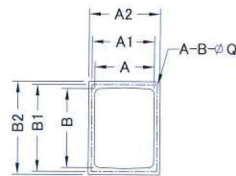

BASE-ACEK

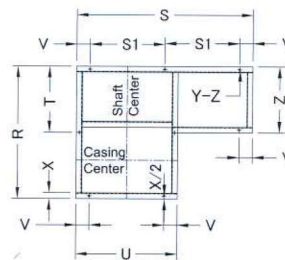

BASE-BDFL

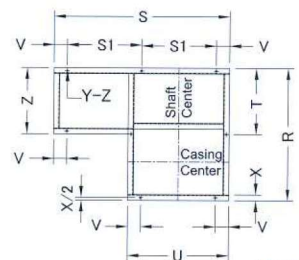

Unit : mm

MODEL	BODY																			BEARING			
	L1	H1	L2	H2	L3	H3	H4	W	HA	HD	HF	HL	D	E	F	G	I	J	K	M	N	L.S	O.S
TF-361B	2082	2180	2465	1927	2659	1876	2100	1628	1000	1300	1150	1150	726	1384	800	1180	655	777	1315	49	685	6312	6314
TF-421B	2434	2447	2927	2154	2927	2104	2387	1789	1100	1500	1300	1300	804	1556	887	1347	772	854	1580	54	770	6313	6315
TF-481B	2715	2735	3250	2400	3508	2340	2685	2036	1200	1650	1400	1400	940	1793	1035	1535	860	1000	1715	61	885	6317	6319
TF-541B	2990	2950	3570	2620	3864	2650	3017	2290	1250	1850	1500	1600	1050	1994	1167	1700	950	1120	1870	55	990	6319	6321
TF-601B	3094	3205	3795	2754	4089	2772	2945	2393	1300	2000	1550	1700	1090	2199	1197	1905	1075	1200	1905	101	1010	6319	6321
TF-721B	3450	3780	4230	3350	4581	3424	3831	3005	1800	2350	1950	2100	1324	2531	1481	2180	1200	1400	2050	180	1200	6320	7322

MODEL	OUTLET FLANGE						INLET FLANGE					BASE							DRAIN	W.T		
	A	B	A1	B1	A3	B2	A-B-øQ	øC	øC1	øC2	P-øQ	R	S	S1	T	U	V	X	Z	Y-øZ	ø	(kg)
TF-361B	700	900	775	975	850	1050	40-ø11	900	960	1020	32-ø11	1500	2000	850	750	1370	150	65	750	8-ø16	1-1/2"	560
TF-421B	800	1000	875	1075	950	1150	42-ø11	1000	1060	1120	36-ø11	1640	2350	1025	820	1540	150	65	760	8-ø16	1-1/2"	940
TF-481B	950	1200	1030	1280	1100	1350	50-ø11	1200	1285	1350	44-ø11	1900	2600	1150	950	1770	150	75	850	8-ø16	1-1/2"	1320
TF-541B	1000	1350	1070	1420	1150	1500	52-ø11	1350	1435	1500	48-ø11	2075	2860	1280	1038	1980	150	75	910	8-ø16	2"	1450
TF-601B	1100	1500	1190	1590	1280	1680	60-ø11	1500	1565	1630	52-ø11	2180	2900	1300	1090	2020	150	75	950	8-ø16	2"	1600
TF-721B	1440	1800	1520	1880	1600	1960	64-ø12	1800	1880	1960	64-ø12	2600	3250	1475	1300	2400	150	75	960	8-ø16	2"	2600

DIMENSION DRAWING

TF-121 151 181 211 241 271 301 331 Coupling Drive

Side view from the inlet

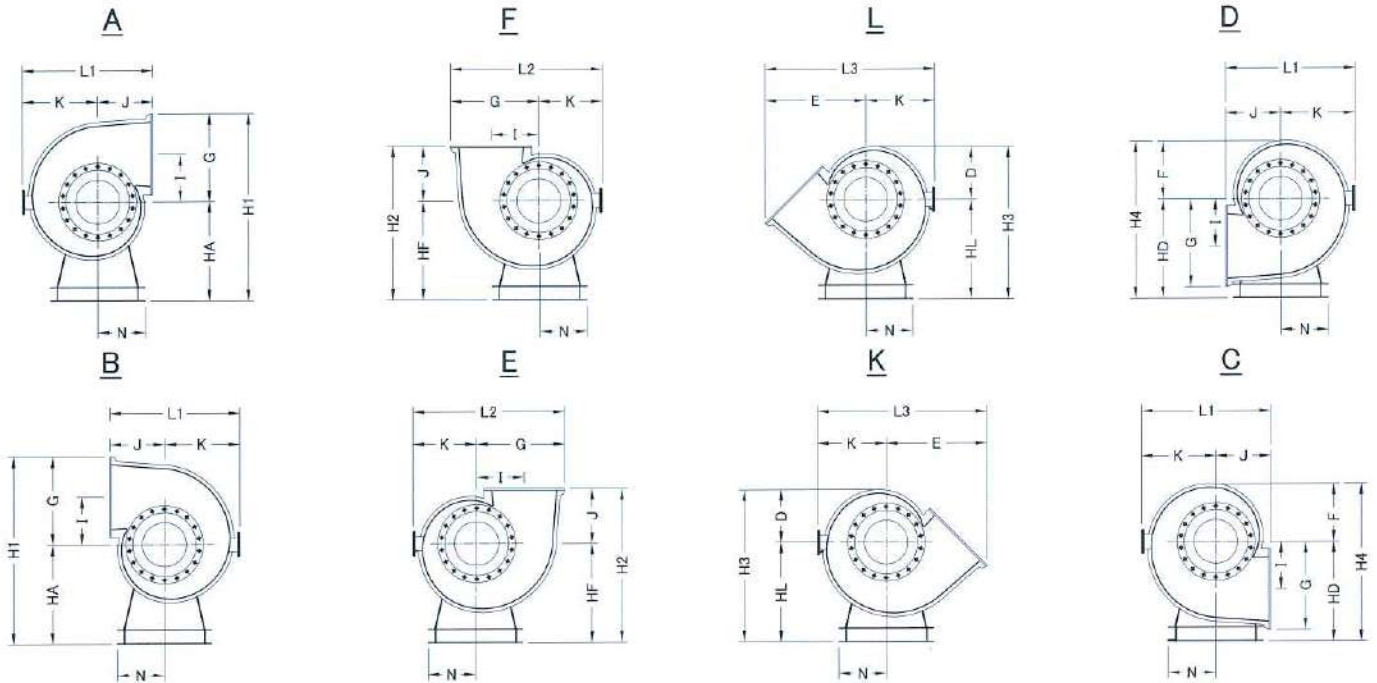

BODY

OUTLET

BASE

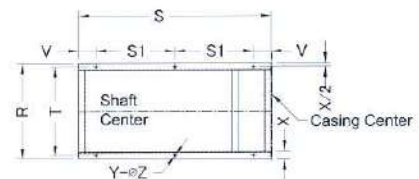
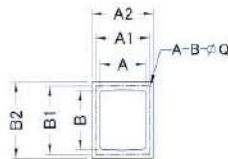
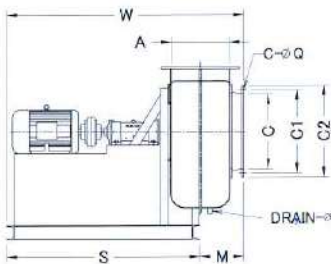

Unit : mm

MODEL	BODY																				BEARING		
	L1	L2	L3	W	H1	H2	H3	H4	HA	HF	HL	HD	D	E	F	G	I	J	K	M	N	L.S	O.S
TF-121C	630	700	800	1138	840	720	700	720	450	450	450	450	250	467	270	390	195	270	360	198	225	6308	6307
TF-151C	760	870	980	1240	946	819	817	894	450	500	500	550	317	576	344	496	271	318	442	240	258	6308	6307
TF-181C	915	1060	1190	1545	1170	988	972	1122	550	600	600	700	372	712	422	620	335	387	528	295	300	6309	6307
TF-211C	1040	1200	1365	1724	1290	1150	1122	1265	600	700	700	800	422	806	465	690	380	450	590	324	350	6311	6309
TF-241C	1195	1371	1544	1847	1590	1300	1282	1431	800	800	800	900	482	912	531	790	430	500	695	357	370	6311	6309
TF-271C	1335	1526	1723	1977	1600	1410	1377	1526	750	850	850	950	527	997	578	850	460	560	676	377	430	6313	6311
TF-301C	1435	1639	1863	2107	1750	1576	1508	1714	800	950	950	1100	556	1114	614	950	480	626	809	407	500	6313	6311
TF-331C	1616	1824	2081	2326	1990	1800	1737	1902	950	1100	1100	1200	637	1230	702	1040	570	700	784	426	600		

MODEL	OUTLET FLANGE						INLET FLANGE					BASE						DRAIN	W.T (kg)	
	A	B	A1	B1	A2	B2	A-B-øQ	øC	øC1	øC2	C-øQ	R	S	S1	T	V	X			Y-øZ
TF-121C	220	300	265	345	310	390	14-ø11	300	345	390	12-ø11	450	940	370	410	100	40	6-ø16	3/4"	100
TF-151C	280	350	330	400	380	450	14-ø11	350	400	450	12-ø11	515	1000	400	475	100	40	6-ø16	3/4"	250
TF-181C	350	450	410	510	470	570	22-ø11	450	500	550	16-ø11	600	1250	525	550	100	50	6-ø16	1"	300
TF-211C	400	500	467	567	520	620	22-ø11	500	550	600	20-ø11	700	1400	600	650	100	50	6-ø16	1"	350
TF-241C	490	600	550	660	610	720	24-ø11	600	650	700	22-ø11	740	1490	645	690	100	50	6-ø16	1"	400
TF-271C	500	650	585	715	630	780	30-ø11	650	710	770	24-ø11	860	1600	700	810	100	50	6-ø16	1"	460
TF-301C	550	800	620	870	690	940	32-ø11	750	800	850	27-ø11	1000	1700	700	930	150	65	6-ø16	1"	550
TF-331C	600	800	670	870	740	940	32-ø11	800	870	940	32-ø11	1200	1900	800	1135	150	65	6-ø16	1"	650

TF-361 421 481 541 601 721 Coupling Drive

Side view from the inlet

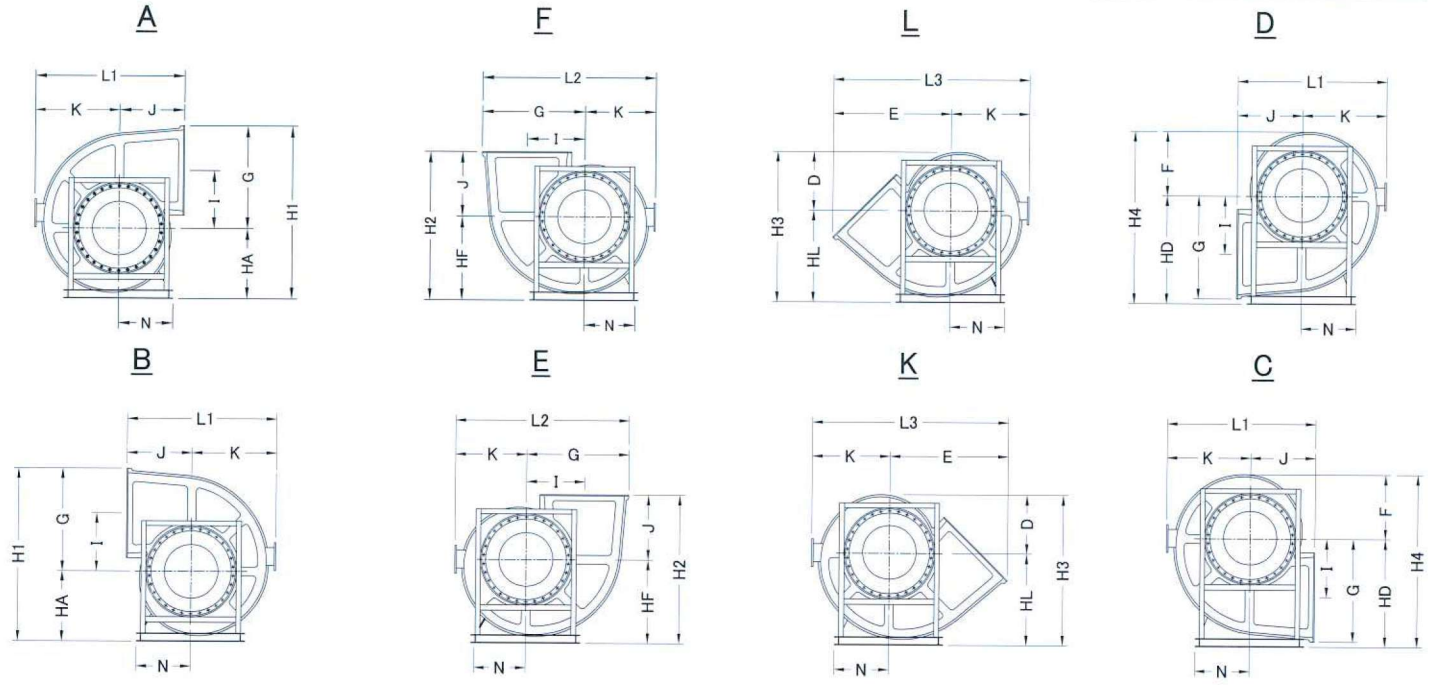

BODY

OUTLET

BASE

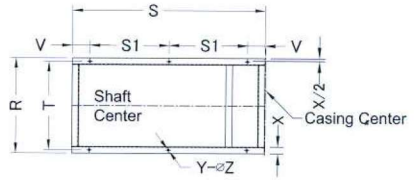
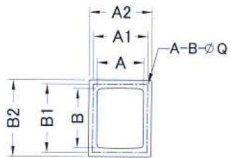
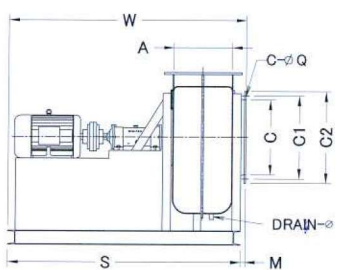

Unit : mm

MODEL	BODY																				BEARING		
	L1	L2	L3	W	H1	H2	H3	H4	HA	HF	HL	HD	D	E	F	G	I	J	K	M	N	L.S	O.S
TF-361C	1785	2039	2321	2499	2180	1927	1876	2099	1000	1150	1150	1300	726	1384	800	1180	655	777	1008	49	685	6312	6314
TF-421C	2012	2297	2606	2762	2447	2154	2104	2387	1100	1300	1300	1500	804	1556	887	1347	772	854	1167	62	775	6313	6315
TF-481C	2285	2620	2979	3061	2735	2400	2340	2685	1200	1400	1400	1650	940	1793	1035	1535	860	1000	1285	61	885	6317	6319
TF-541C	2600	2948	3388	3255	2950	2620	2650	3017	1250	1500	1600	1850	1050	1994	1167	1700	950	1120	1480	55	910	6319	6321
TF-601C	2705	3206	3613	3496	3205	2750	2790	3247	1300	1550	1700	2050	1090	2203	1197	1905	1075	1200	1505	96	935	6319	6321
TF-721C	3230	3701	4209	4080	3780	3350	3424	3831	1600	1950	2100	2350	1324	2531	1481	2180	1200	1400	1836	180	1120	6320	7322

MODEL	OUTLET FLANGE						INLET FLANGE				BASE						DRAIN	W.T		
	A	B	A1	B1	A2	B2	A-B-øQ	øC	øC1	øC2	C-øQ	R	S	S1	T	V	X	Y-øZ	ø	(kg)
TF-361C	700	900	775	975	850	1050	40-ø11	900	960	1020	32-ø11	1370	2450	1075	1305	150	65	6-ø16	1-1/2"	800
TF-421C	800	1000	890	1090	950	1150	42-ø11	1000	1060	1120	36-ø11	1550	2700	1200	1475	150	75	6-ø16	1-1/2"	940
TF-481C	950	1200	1030	1280	1100	1350	50-ø11	1200	1285	1350	44-ø11	1770	3000	1350	1695	150	75	6-ø16	1-1/2"	1320
TF-541C	1000	1350	1070	1420	1150	1500	52-ø11	1350	1435	1500	48-ø11	1820	3200	975	1795	150	75	8-ø16	2"	1600
TF-601C	1100	1500	1190	1590	1280	1680	60-ø11	1500	1565	1630	52-ø11	1870	3400	1050	1795	150	75	8-ø16	2"	1900
TF-721C	1440	1800	1520	1880	1600	1960	64-ø12	1800	1880	1960	64-ø12	2240	3900	1200	2165	150	75	8-ø16	2"	2200

Technical data

Drive Type

Belt Drive

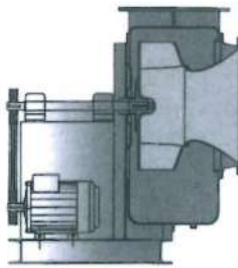

Coupling Drive

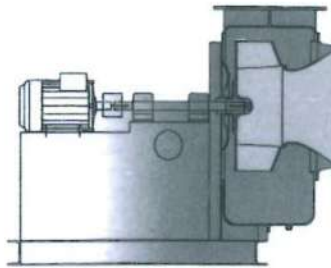

Direct Drive

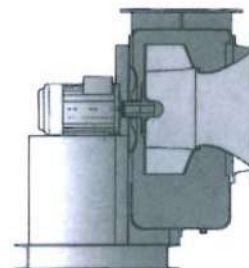

Arrangements

A

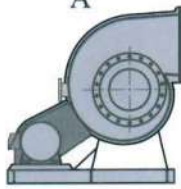

B

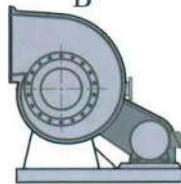

C

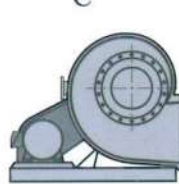

D

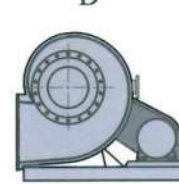

E

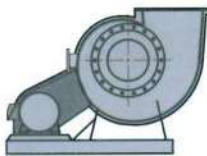

F

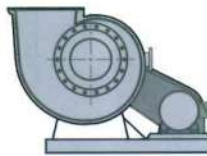

K

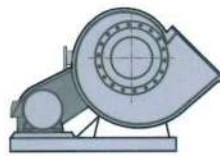

L

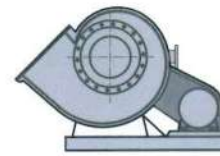

- The fan arrangement is subject to the fan outlet direction.
- Customized orientation is also available.



Winfan (M) Sdn. Bhd. (1063911-K)

TEL : +604-506 2335
FAX : +604-506 2435
Mobile : +6017-297 2335
E-mail : info@winfan.my
Website : <http://www.winfan.my>
Address : PMT31, Jalan IKS Simpang Empat,
Taman IKS Simpang Empat,
14100 Simpang Ampat, Penang, Malaysia.